

HydroFoamer Models 481 and 483

Package Contains:

- | | |
|---|--|
| 1. Injection molded assembly:
foaming barrel, handle, and eductor. | 3. Suction tube/strainer. |
| 2. Concentrate container:
Model 481 - 96 oz., Model 483 - 48 oz. | 4. Spray gun with quick disconnect assembly. |
| | 5. Metering tip kit. |
| | 6. Product information sheet. |

THANK YOU FOR YOUR INTEREST IN OUR PRODUCTS

Please use this equipment carefully and observe all warnings and cautions.

***** NOTE *****

WEAR	protective clothing and eyewear when dispensing chemicals or other materials.
ALWAYS	observe safety and handling instructions of the chemical manufacturers.
ALWAYS	direct discharge away from you or other persons or into approved containers.
ALWAYS	dispense cleaners and chemicals in accordance with manufacturer's instructions. Exercise CAUTION when maintaining your equipment.
CLEAN	equipment after each use in accordance with instruction sheet.
WEAR	protective clothing and eyewear when working in the vicinity of all chemicals, filling or emptying equipment or changing metering tips.
ALWAYS	re-assemble equipment according to instruction procedures. Be sure all components are firmly screwed or latched into position.
ATTACH	only to tap water outlets (85 PSI maximum).

Operation:

1. Unscrew foamer lid assembly from container.
2. Select a metering tip using the chart below as a guideline and press the tip firmly into the hose barb on the bottom of the lid assembly. Install the suction tube on the hose barb.
3. Fill the container with concentrate. Screw foamer lid assembly securely onto container.

CAUTION: Foamer lid assembly must be securely fastened to container to prevent accidental spilling of concentrate during use of foamer.

4. Insert foamer lid assembly into female quick connect on spray gun.
5. Connect a garden hose with 3/4" male garden hose thread to the base of the spray gun handle. Turn on the water supply to the hose. (Minimum 25 PSI water pressure is required to operate the foamer.)
6. Grasp the spray gun handle in one hand and the foamer container in the other. Squeeze the spray gun handle to begin foaming. Continuous operation can be achieved by using the handle lock provided on the spray gun. Rinse by disconnecting the spray gun from the foaming lid assembly. To remove the foamer from the spray gun, simply grasp the quick connect on the spray gun in one hand and the foamer assembly in the other. Pull in opposite directions. (The outside collar around the quick connect will slide toward the spray gun, disengaging the foamer barrel.)

Metering Tip Selection:

Dilution ratios below were achieved at 40 PSI, cold water and water-thin viscosity (1.0 CP). Ratios will vary given PSI, water and ambient temperature, water flow rate, and product viscosity. At water-thin viscosity, the efficiency of the eductor is at its maximum with the black or gray tip. Removal of the foot strainer on the concentrate pick-up tube will also change these ratios. *If no tip is listed, the dilution ratio delivered falls between those shown.

Tip Color	Drill Size	Ratio	Oz/Gal.
No Tip		12:1	10
Gray	30	*	*
Black	40	*	*
Beige	50	*	*
Red	55	*	*
White	57	14:1	9
Blue	60	16:1	8
Tan	65	18:1	7
Green	70	26:1	5
Orange	72	32:1	4
Brown	74	*	*
Yellow	76	42:1	3
Aqua	77	*	*
Purple	79	64:1	2
Pink	87	128:1	1

Troubleshooting:

Problem	Cause	Remedy
1. Unit does not draw concentrate	a. Clogged suction tube strainer b. Metering tip orifice obstructed c. Water pressure too low d. Mineral deposits in barrel of foamer	a. Clean or replace b. Rinse tip or replace: Do not attempt to clean: may alter size of orifice c. Minimum 25 PSI required d. Back flush unit. Remove container, suction tube and metering tip. Put finger over barrel opening. Apply minimal water pressure through garden hose at nozzle of barrel to be flushed. d. Descale foamer by soaking in weak descaling solution. e. Clean or replace strainer.
2. Weak foaming action	e. Clogged water inlet strainer (low water flow) a. Clogged water inlet strainer b. Water pressure too low c. Water temperature too high	a. Clean or replace b. Minimum 25 PSI required c. Use lower temp water source. (Concentrate flow decreases above 140° F water)

If above steps fail to produce good concentrate draw and/or foaming action, replace lid assembly. See component chart below.

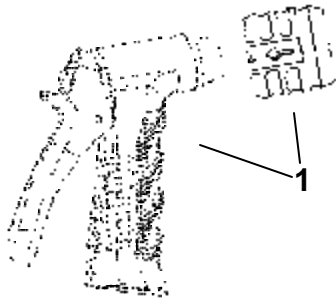

HydroFoamer Parts List

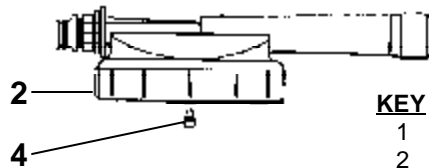

KEY	PART NO.	DESCRIPTION
1	10083713	Spray gun & quick disconnect
2	10061501	Foamer lid assembly
3	688201	Concentrate container - 96 oz.
	688202	Concentrate container - 48 oz.
4	690014	Metering tip kit
5	500808	Suction tube, 8"
6	609600	Foot strainer

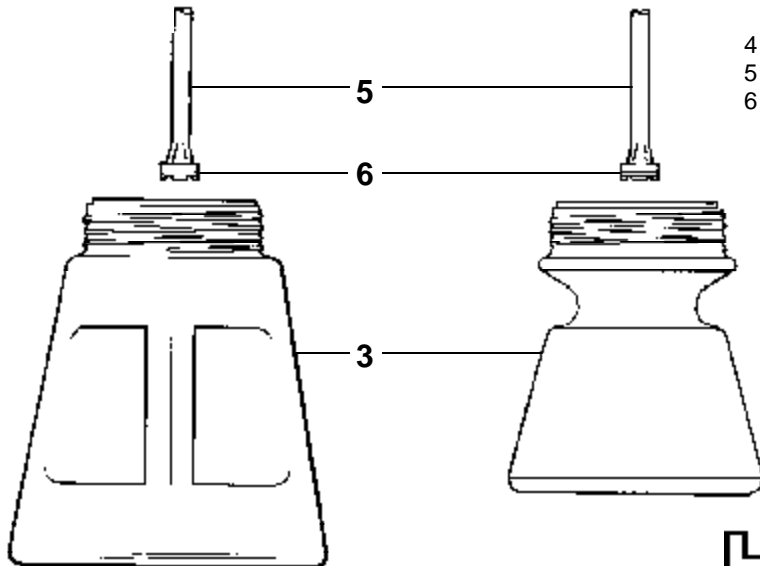

Hydro Systems Company
 3798 Round Bottom Road
 Cincinnati, OH 45244 USA
 Phone: (513) 271-8800