

Trouble-shooting Chart:

Problem	Cause	Remedy
1. No concentrate draw	a. Clogged check valve b. Metering tip or eductor clogged c. Low water pressure d. Clogged foot strainer e. Concentrate container empty f. Suction stub not screwed into eductor tightly	a. Clean or replace b. Clean (descale) or replace* c. Minimum 25 PSI required to operate unit d. Clean or replace e. Replace with full container f. Tighten
2. Excess concentrate draw	a. Metering tip not in place	a. Screw tip firmly into eductor suction stub
3. Low or no water flow	a. Inlet screen clogged b. Supply source inadequate c. Scale build-up on eductor or fittings	a. Clean inlet screen (also check screen inside backflow preventer) b. 5 GPM inlet flow required. Move unit to adequate source or replumb incoming line. c. Clean or replace*
4. Backflow into concentrate	a. Eductor check valve inoperable	a. Clean or replace check valve
<p>* In hard water areas, scale may form at the discharge of the eductor or other fittings. This scale may be removed by soaking in a descaling (deliming) solution or by running the descaling solution through the system. If descaling solution is educted through unit, let it run through unit for a minute, then flush the system by educting clear water through it. Then return suction tube foot strainer to concentrate.</p>		

FoamMaster Model 865 Compressed Air Power Cleaning System

Package Contains:

1. FoamMaster manifold assembly
2. Metering tip kit
3. Suction tube, 6 ft. with strainer
4. Instruction sheet
5. Hose assembly

THANK YOU FOR YOUR INTEREST IN OUR PRODUCTS

Hydro Systems manufactures quality chemical proportioners. Please use this equipment carefully and observe all warnings and cautions.

***** NOTE *****

WEAR	protective clothing and eyewear when dispensing chemicals or other materials.
ALWAYS	observe safety and handling instructions of the chemical manufacturers.
ALWAYS	direct discharge away from you or other persons or into approved containers.
ALWAYS	dispense cleaners and chemicals in accordance with manufacturer's instructions. Exercise CAUTION when maintaining your equipment.
KEEP	equipment clean to maintain proper operation.
WEAR	protective clothing and eyewear when working in the vicinity of all chemicals, filling or emptying equipment or changing metering tips.
ALWAYS	re-assemble equipment according to instruction procedures. Be sure all components are firmly screwed or latched into position.
ATTACH	only to tap water outlets (85 PSI maximum).

Through proper care and maintenance, this equipment will serve your toughest cleaning jobs.

Installation:

1. Remove either the 3/4" or 2" bung from an upright drum. Insert the foot valve end of supply tube into drum. Put the open end of the tube through the center hole in the drum adapter. Swivel drum adapter several turns onto drum until secure.
2. Select a metering tip using the chart in these instructions as a **guideline** and screw it firmly into the eductor suction stub. Install the open end of the suction tube of the metering tip and suction stub.
3. Connect the FoamMaster to the water supply through an adjustable pressure regulator to allow best operation and foam quality. Connect the regulated water supply to the garden hose swivel water inlet at the left side of the FoamMaster.
4. Connect a compressed air line to the quick fitting supplied at the top left side of the FoamMaster.
5. Connect the discharge hose assembly to the hose barb on the manifold outlet. Tighten the hose clamp securely around the discharge hose over the hose barb fitting.

Operation:

The FoamMaster has shut-off valves in the water and air supply lines, and an air pressure gauge. These components will be used, along with the metering tips, to regulate foam quality.

1. Begin with the air supply valve off. Holding the end of the discharge hose, turn the water supply on, and adjust the water supply regulator to bring the water to approximately 40 PSI flowing. Confirm that product is being drawn up the supply tube to the eductor. **Note:** The minimum flowing water pressure to operate the unit is 25 PSI.
2. Open the compressed air supply needle valve until the air pressure gauge reads approximately 30 PSI with air, water and product flowing.



Proportioning & Dispensing Equipment

Hydro Systems Company
3798 Round Bottom Road
Cincinnati, OH 45244 USA
Phone: (513) 271-8800
Fax: (513) 271-0160

3. Foam character adjustment:

The nature of the foam can be varied by changing the amount of concentrate drawn, water pressure and/or air pressure. Different products will perform differently in the FoamMaster due to viscosity, foaming nature, etc.

- a) A larger diameter metering tip increases concentration, creating a thicker, richer foam.
- b) More air pressure tends to deliver thicker, drier foam and will increase throw of foam. However, it can destroy foam quality if concentration of the product is too low.
- c) Lower water pressure tends to create drier foam. In most situation, best results are achieved with air pressure no higher than the water pressure.

Measurement of Concentration:

Final dilution is related to the size of the orifice in the metering tip used and product viscosity. The ratio is also affected by water pressure, temperature and flow rate.

You can determine the dispensed water-to-product ratio for any metering tip size and product viscosity. All that is required is to operate the primed dispenser for a minute or so and note two things; the amount of dispensed water-to-product solution and the amount of concentrate used in preparation of the solution dispensed. The water-to-product ratio is then calculated as follows:

$$\text{Dilution (X)} = \frac{\text{Amount of Mixed Solution Dispensed}}{\text{Amount of Concentrate Drawn}}$$

Dilution ratio, then, equals X parts water to one part concentrate (X:1). If the test does not yield the desired ratio, choose a different tip and repeat the test.

Alternative methods to this test are 1) pH (using litmus paper), and 2) titration. Contact your concentrate supplier for further information on these alternative methods and the materials required to perform them.

Tip Guide:

Tip Color	Drill Size	Approximate Dilution Ratio at 40 PSI and water-thin viscosity (1.0 cp)	oz./gal.	Percent Solution
Pink	89	129:1	1.0	0.77%
Purple	79	79:1		1.25%
Yellow	76	67:1		1.47%
Brown	74	63:1	2.0	1.56%
Orange	72	53:1	3.0	1.85%
Green	70	41:1		2.38%
Tan	64	26:1		3.70%
Blue	60	22:1		4.35%
White	57	19:1	8.0	5.00%
Red	55	13:1		7.14%
Beige	50	9:1	16	10.00%
Black	40	7:1		12.50%
Grey	30	6:1		14.39%
No Tip	----	5:1	32	16.67%

FoamMaster Model 865 Parts Diagram/List

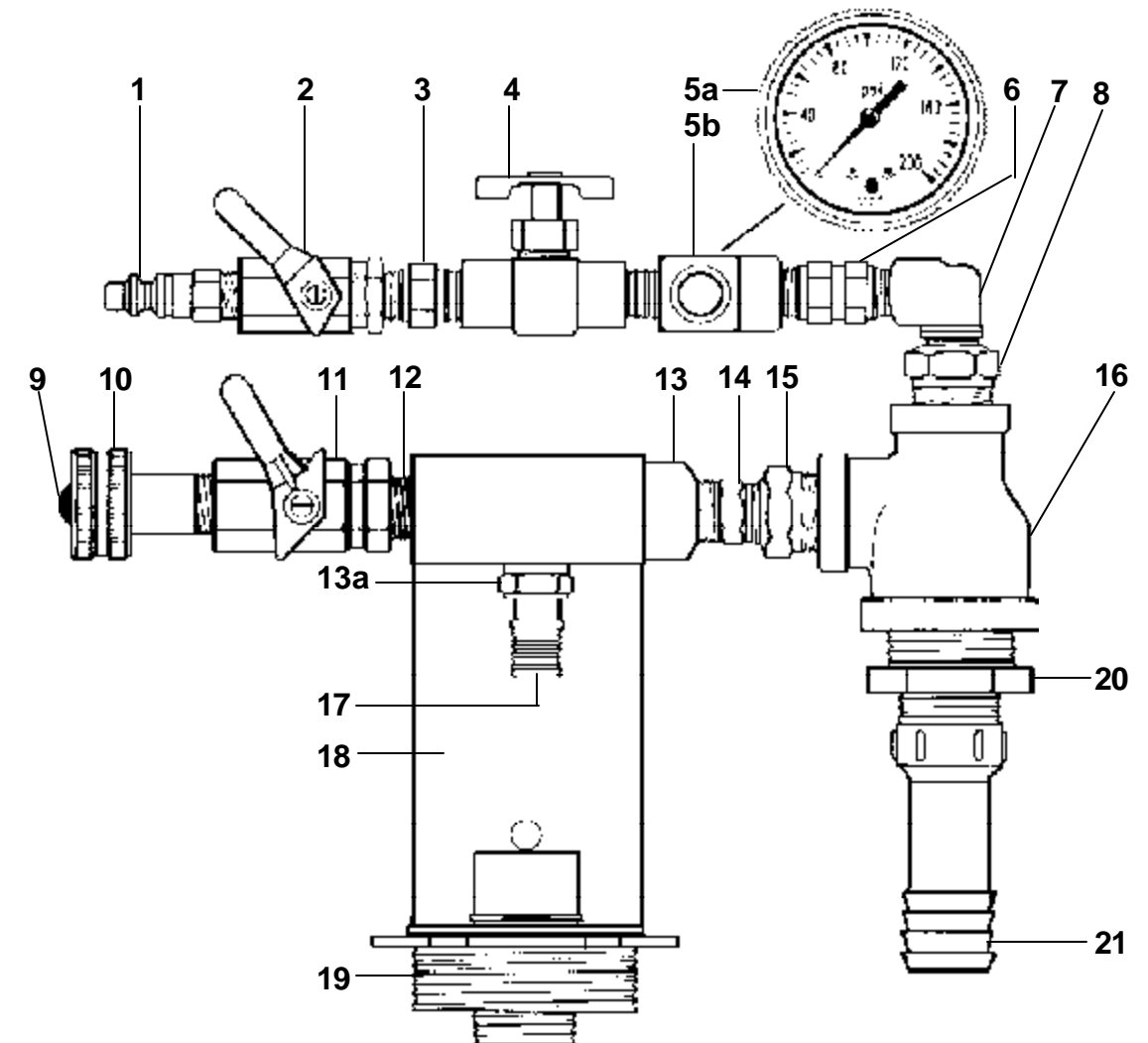

Key	Part No.	Description	Key	Part No.	Description
1	419342	Air inlet quick coupling	13a	636900	Check valve
2	502000	Ball valve	14	637900	Hex nipple
3	234300	Hex nipple	15	2330-R	Bushing
4	419313	Needle valve	16	419303	Reducing tee
5a	10083000	Pressure gauge (0-200 PSI)	17	690015	Metering tip (inside barb) - kit
5b	620100	Tee for pressure gauge	18	615000	Bracket
6	419302	Check valve	19	6162-A	Bung adaptor assembly
7	505600	Street elbow	20	271900	Bushing, 3/4" x 1"
8	371300	Reducing bushing	21	419337	3/4" PVC hose nipple
9	238100	Strainer washer	NOT SHOWN:		
10	276700	Swivel connector	419301		Nozzle (inside Key #16)
11	607600	Ball valve	6400-A		Suction tube, 1/2" x 6'
12	230200	Close nipple	372900		Clamp
13	203700	Eductor assembly, 3.5 GPM (includes 13a check valve)	419339		3/4" clear hose (discharge)
			419340		Vinyl hose guard